

# AVR ATxmega Development Module

**Model: AL-XAVRB**

- Summary
- Measures
- Description
- Electrical Characteristics
- Programming
- Settings

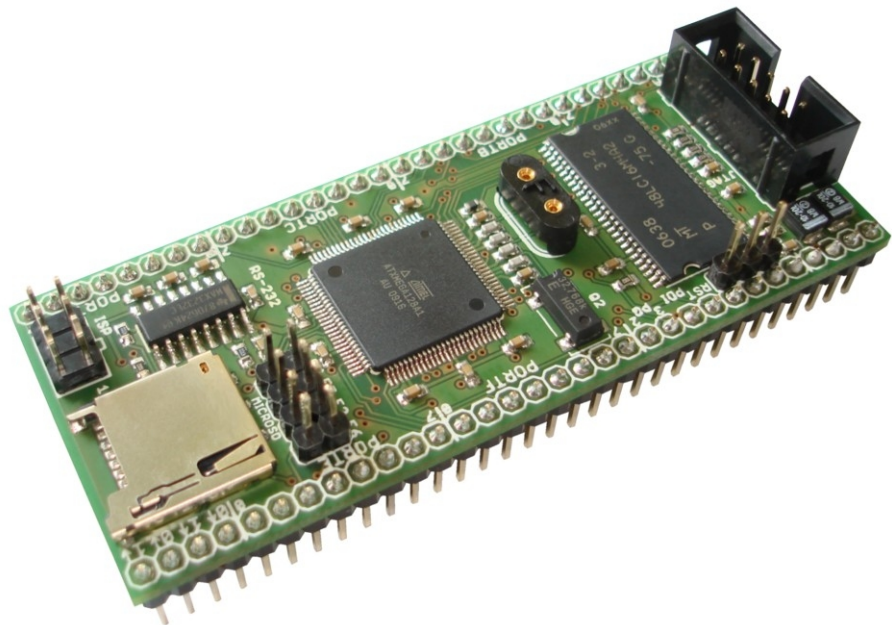

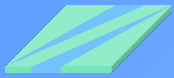

## Summary

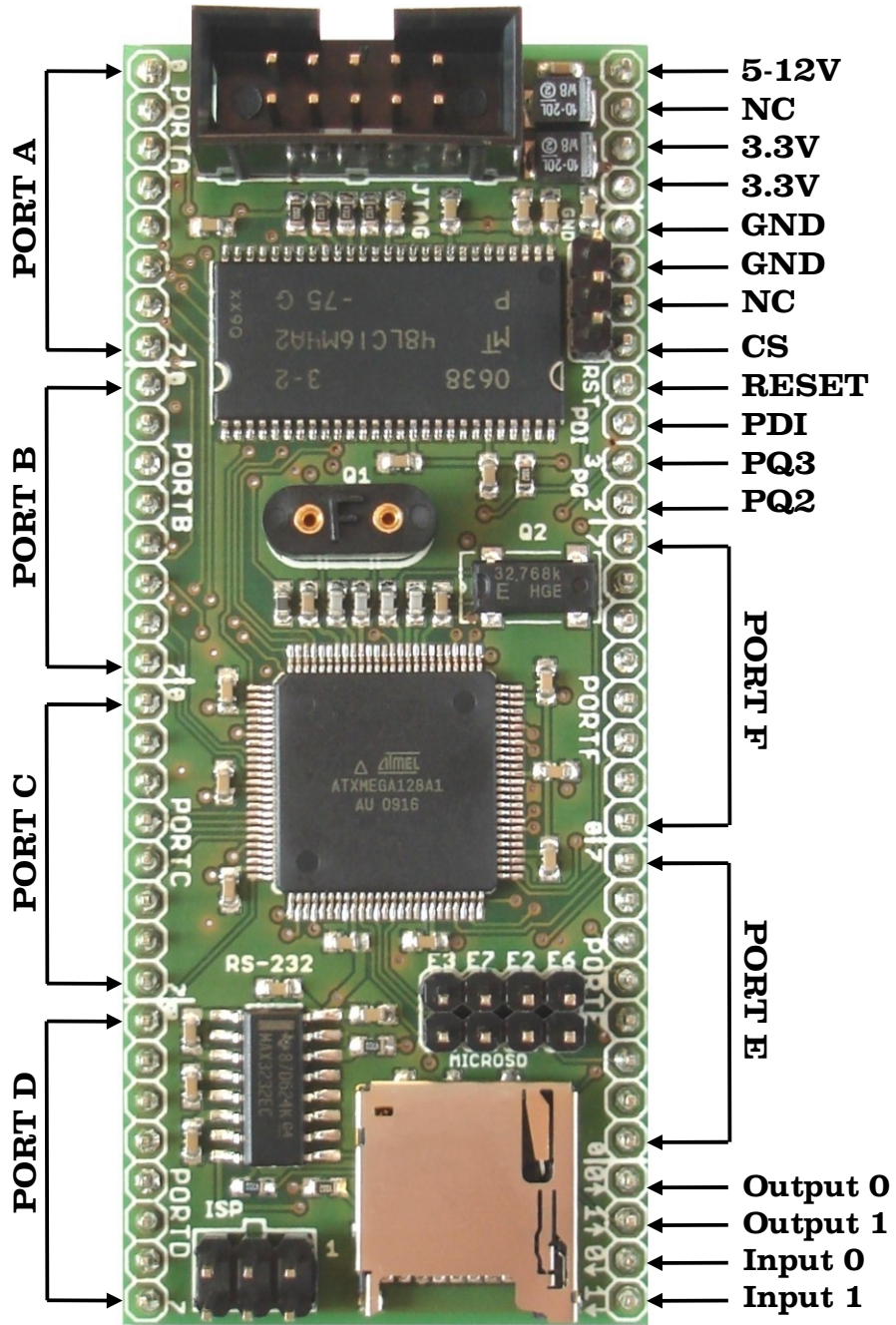

**Attention! Polarity reversal and overvoltage may cause a destruction of the electronic components!!!**

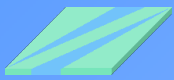

## Measures

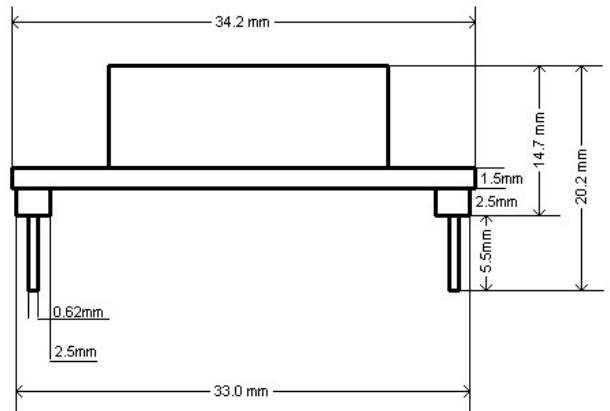
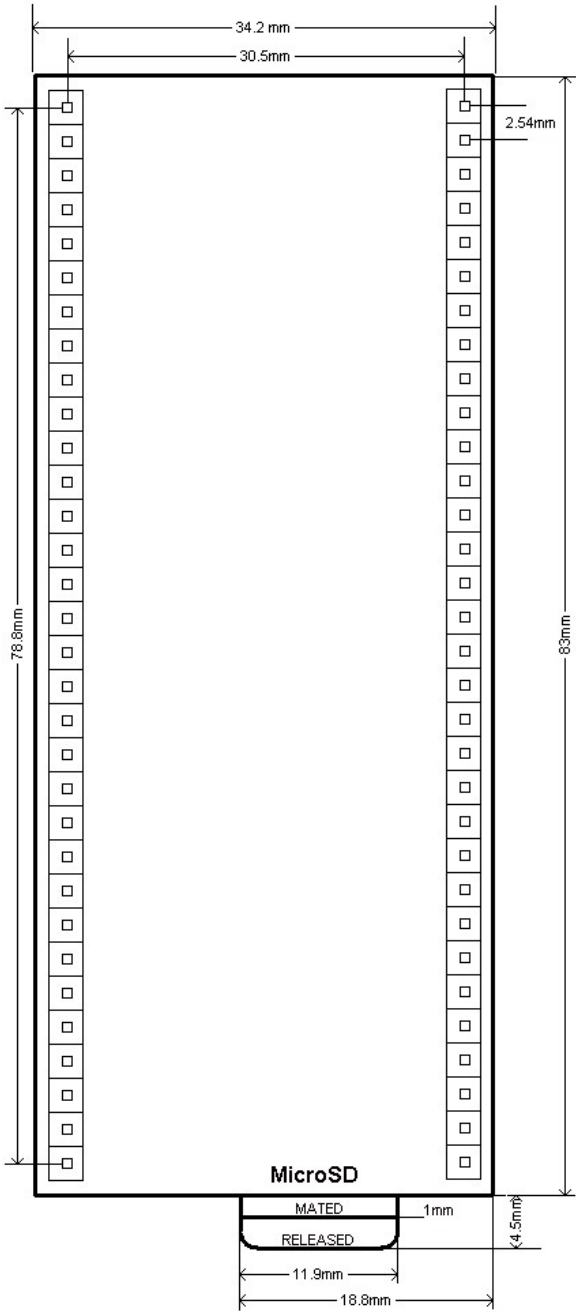

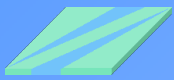

## Description

01_PA0	64_5-12V
02_PA1	63_NC
03_PA2	62_VCC+L
04_PA3	61_VCC-L
05_PA4	60_GND
06_PA5	59_GND
07_PA6	58_NC
08_PA7	57_CS
09_PB0	56_RESET
10_PB1	55_PDI
11_PB2	54_PQ3
12_PB3	53_PQ2
13_PB4	52_PQ7
14_PB5	51_PQ6
15_PB6	50_PQ5
16_PB7	49_PQ4
17_PC0	48_PQ3
18_PC1	47_PQ2
19_PC2	46_PQ1
20_PC3	45_PQ0
21_PC4	44_PE7
22_PC5	43_PE6
23_PC6	42_PE5
24_PC7	41_PE4
25_PD0	40_PE3
26_PD1	39_PE2
27_PD2	38_PE1
28_PD3	37_PQ0
29_PD4	36_RS232OUT0
30_PD5	35_RS232OUT1
31_PD6	34_RS232IN0
32_PD7	33_RS232IN1

AVR\_ATXMEGA\_MODULE  
 AVR\_ATXMEGA128A1\_MODULE

- **Controller:** Atmel AVR ATxmega128A1-AU up to 32 MHz
- **Additional equipping:**
  - internal voltage regulator 3.3V
  - external SDRAM 64Mbit
  - MicroSD card slot
  - RS-232 Transceiver
- **Voltage supply:**
  - external 3.3V or
  - external 5.0-12V
- **Module size:** W x H x D 34mm x 83mm x 19.3mm
- **external quartz:**
  - quartz socket
  - external 32.768KHz quartz
- **PC-Connection:** 2 x RS232, separable with jumpers
- **Compatibility:** compatible with hole matrix board and hole-distance 2.54 mm
- **Circuit:** built on the recommendation of the manufacturer
- **Programming:**
  - JTAG MKII connector or
  - AVR ISP MKII connector
- **Pin configuration ISP & JTAG:**
  - ISP(PDI) 6-pin, standard of Atmel
  - JTAG connector 10-pin, standard of Atmel
- **Pin configuration of AVR-Module:** shown at the left picture
- **Conformity:** **RoHS Compliance**
- **Produced in Germany**

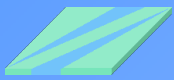

## Electrical Characteristics

	Min	Typ	Max
--	-----	-----	-----

for <b>all</b> modules with	Operating Temperature		
MT48LC16M4A2P-75:G (actual)	0 °C		70 °C
MT48LC16M4A2P-75IT:G	-20 °C		85 °C
on request	-40 °C		85 °C

	Voltage Sources		
external 3,3V	3.0 V	3.3 V	3.6V
external 5-12V *	4.3 V		12 V

	Frequency		
operating frequency	0 Hz		32 MHz
external quartz Q1 (quartz socket)	0 Hz		16 MHz
external quartz Q2		32.768 kHz	

	Maximum DC Current		
per I/O Pin		20 mA	

more electrical characteristics you will find on the page 67 in the data sheet [ATxmega128A1.pdf](#)

- ▶ voltage regulator: TS1117CW-33
- ▶ SDRAM: MT48LC16M4A2P-75:G
- ▶ SD card slot: micro SD push-push
- ▶ RS 232 Transceiver: MAX3232
- ▶ 4-layer PCB DIN ISO 9001
- ▶ with UL-Approbation
- ▶ double-side mounted

\* by using external power supply on pin 5-12V we recommend to supply with low current (by 12V non-stop operation maximum 100 mA), otherwise cooling of the voltage regulator should be provided.

### Possible Modifications

- ▣ with ATxmegaXXXA1-AU
- ▣ with SDRAM: MT48LC32M4A2P-75IT:G
- ▣ with mounted quartz (without quartz socket)
- ▣ without laterally pins

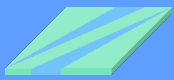

## Programming

### JTAG

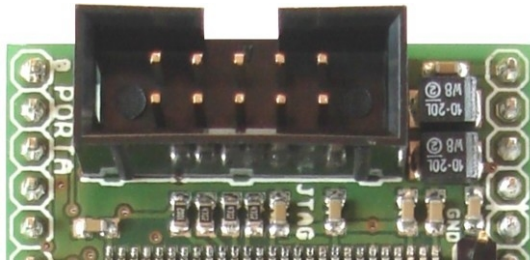

### ISP

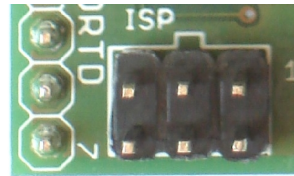

*Pin Configuration  
JTAG-Connector*

(9) TDI	(7) VCC	(5) TMS	(3) TDO	(1) TCK
(10) GND	(8) PDI	(6) RESET	(4) VCC	(2) GND

*Pin Configuration  
ISP-Connector*

(5) RESET	(3)	(1) PDI
(6) GND	(4)	(2) VCC

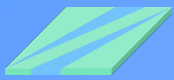

## Settings

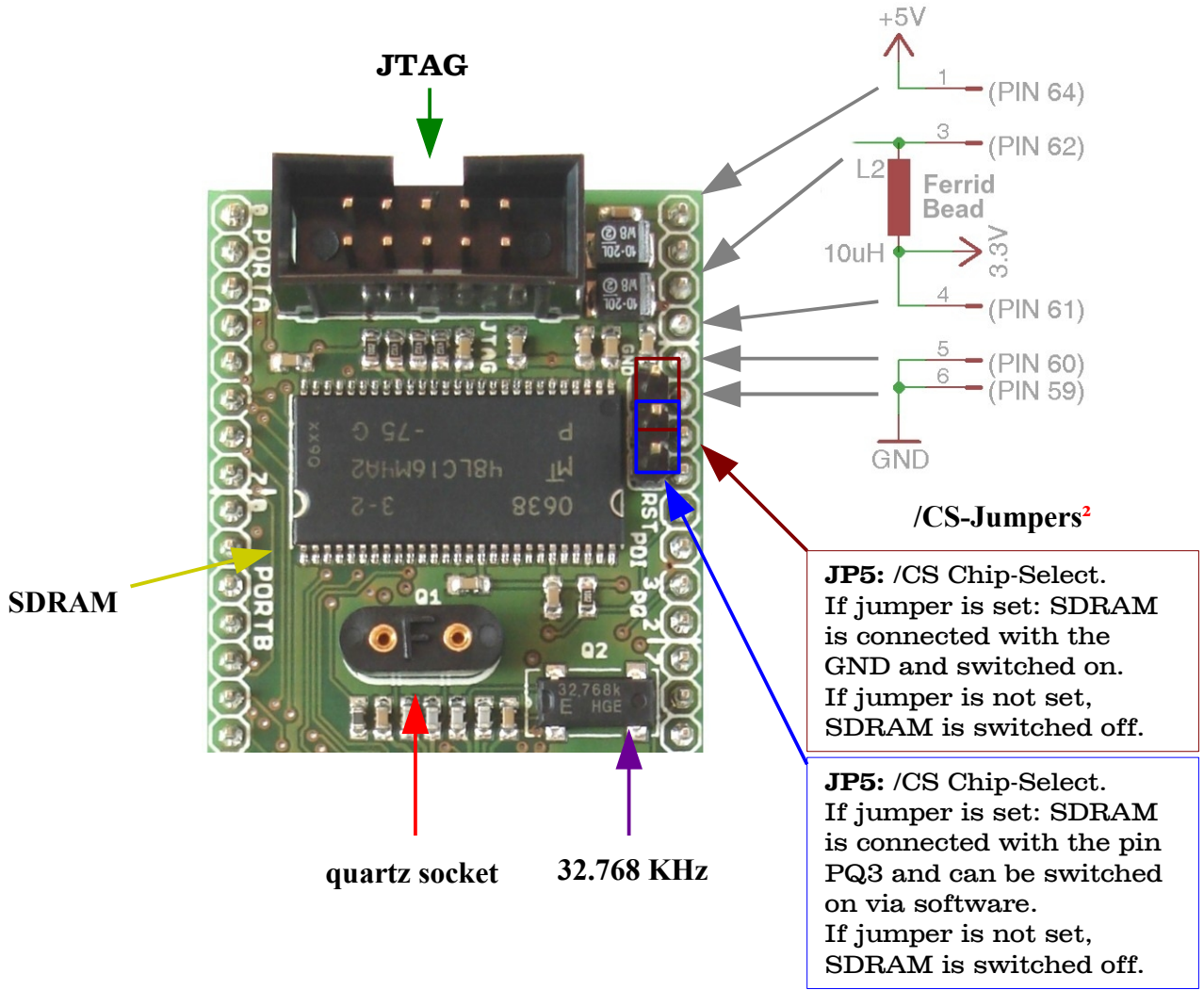

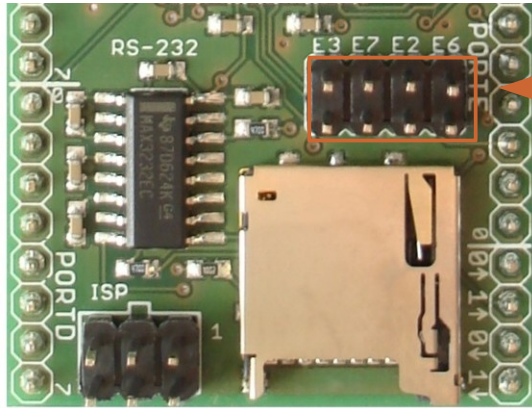

### USART-Jumpers <sup>1</sup>

<b>JP2-1</b>	<b>JP2-2</b>	<b>JP2-3</b>	<b>JP2-4</b>
<b>PE3</b> TxD0	<b>PE7</b> TxD1	<b>PE2</b> RxD0	<b>PE6</b> RxD1

ISP(PDI)

MicroSD card slot

<sup>1</sup> These jumpers separate RS-232 Transceiver from the USART Pins of the controller. While using RS232 the corresponding external USARTs Pins of the module, USARTE0 (external Pins: PE2 and PE3) and USARTE1 (external Pins: Be PE6 and PE7) should be free of any connection.

### Connection of D-SUB 9-pin female connector (serial port/COM1)

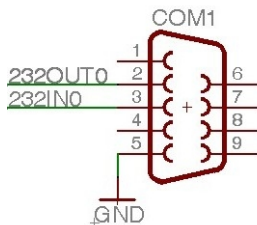

	<b>D-SUB 9-p.</b>	<b>AL-XAVRB</b>
CH 0 example in the left picture	Pin 2	36_RS232OUT 0
	Pin 3	34_RS232IN0
	GND	60_GND
CH 1	Pin 2	35_RS232OUT 1
	Pin 3	33_RS232IN1
	GND	60_GND