

# AVR-Development Module

**Model: AL-AVREB\_CAN**

- **Summary**
- **Measures**
- **Description**
- **Electrical Characteristics**
- **Programming**
- **Settings**

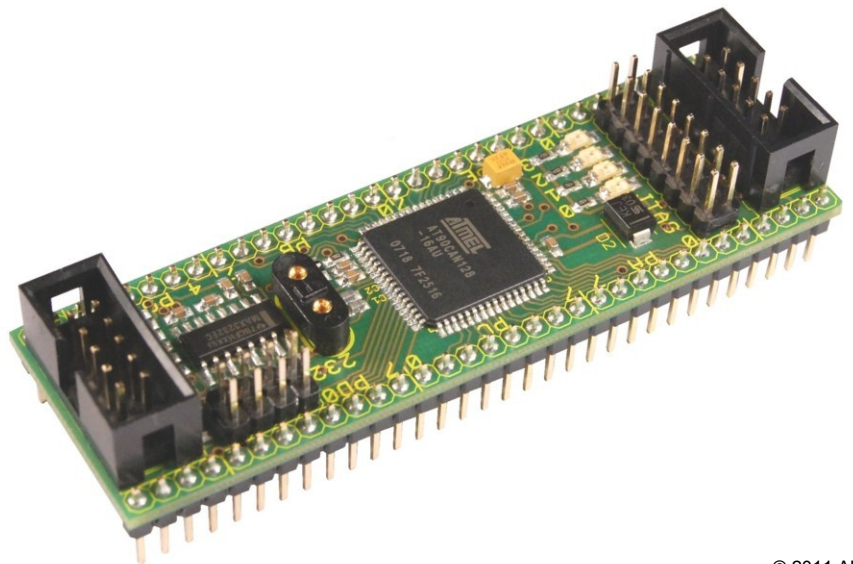

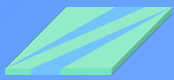

## Summary

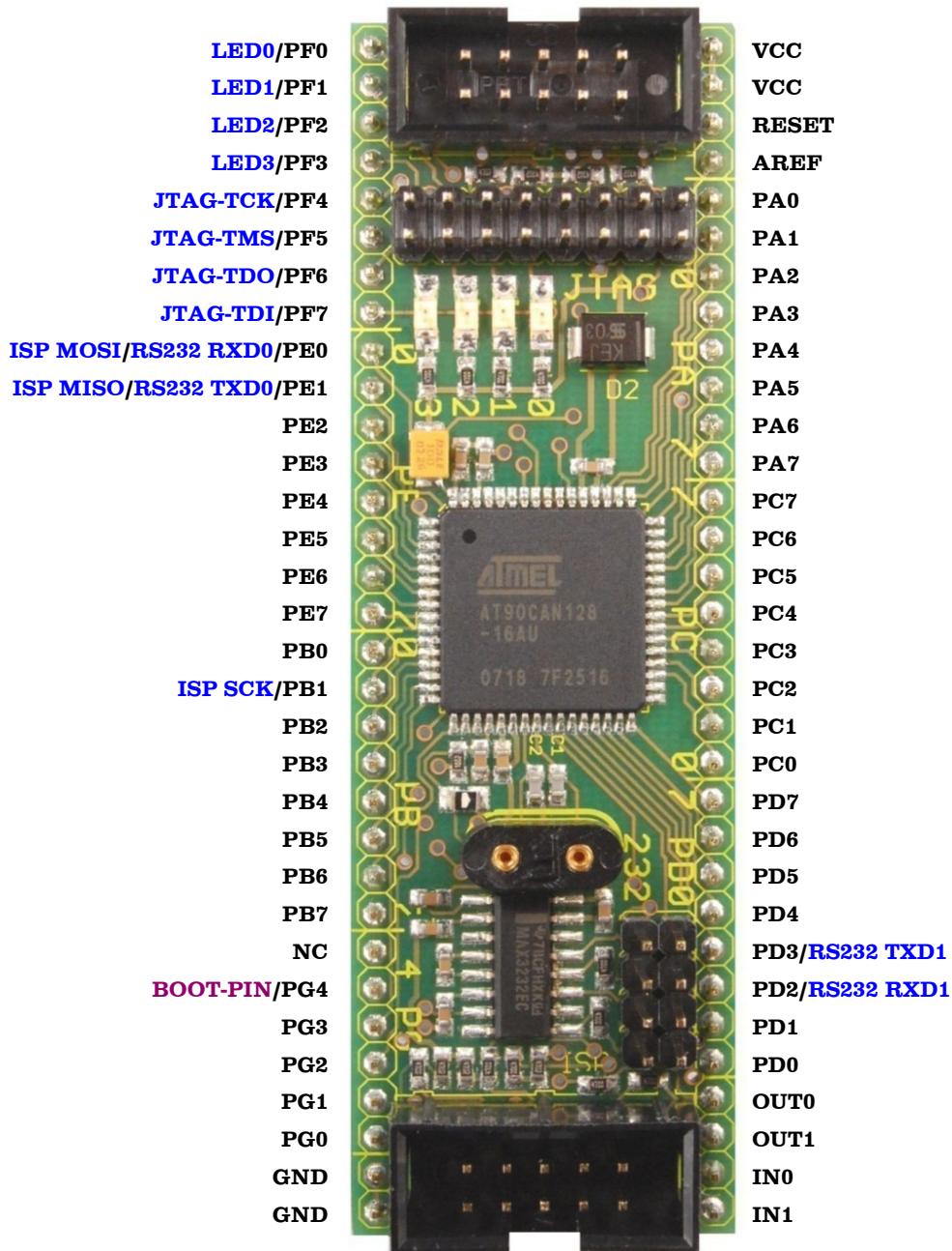

All description in **BLUE** concern the internal connection

**Attention! Polarity reversal and overvoltage may cause a destruction of the electronic components!!!**

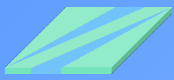

# Measures

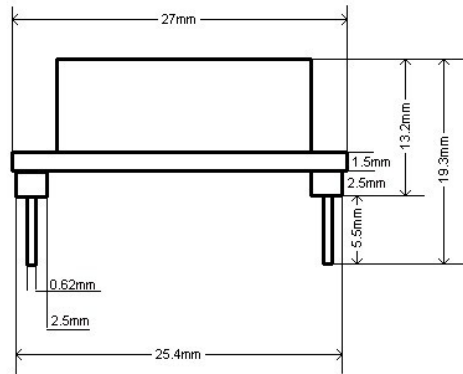
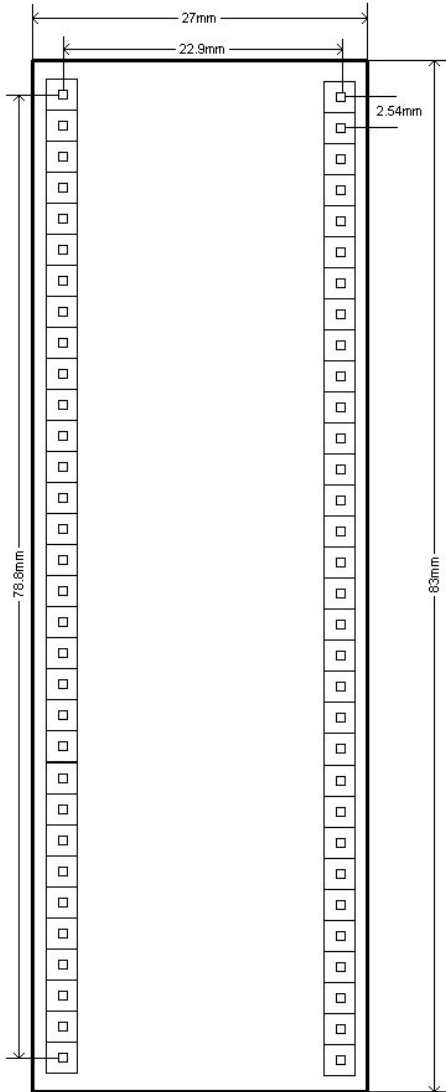

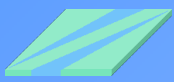

## Description

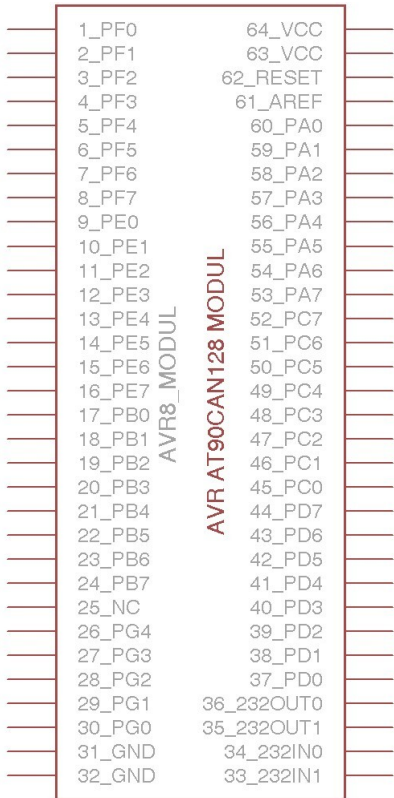

- **Controller:** Atmel AVR AT90CAN128-16AU up to 16 MHz
- **Supply voltage:** 3 - 5V
- **Module size:** W x H x D 27mm x 83mm x 19.3mm
- **Quartz socket:** simple and fast quartz exchange
- **PC-Connection:** 2 x RS232, separable with jumpers
- **Compatibility:** compatible with IC-Socket 64-pin and hole matrix board
- **Pin-Distance:** 2.54 mm
- **LED:** 4 LEDs, separable with jumpers
- **Circuit:** built on the recommendation of the manufacturer
- **Programming:** ISP or JTAG connector
- **Pin configuration of AVR-Module:** shown at the left picture
- **Pin configuration ISP & JTAG connectors:** 10-pin, standard of Atmel
- **Functionality:** tested, ready for use
- **Conformity:** **RoHS Compliance**
- **Produced** in Germany
- **Description:**

We offer you more flexibility by the development. By means of quartz socket it is possible to choose another frequency easier and faster. IC-Socket makes possible the fast installation of AVR-Module and fits the hole matrix board with the hole distance 2.54 mm. All pins of micro controller are connected with the pins of module and positioned in the logical order, that makes the development work easier. The circuit of the module is built on the recommendation of the manufacturer: A/D converter, reset, ISP, JTAG, RS232, LEDs. Jumper configuration helps you to make the right settings. A suppressor diode is responsible for the security of AVR-Module. We offer you a very simple installation and use of AVR-Module for the beginner as well as for the advancer.

# Electrical Characteristics

Min	Typ	Max
-----	-----	-----

for <b>all</b> modules with	Operating Temperature	
MAX3232EID (actual)	- 40 °C	85 °C
MAX3232IDR (actual)		
MAX3232ECD	0 °C	70 °C

	Operating Voltage	
● with maximum frequency 16 MHz	4.5 V	5.5 V
● with maximum frequency 8 MHz	3.0 V	5.5 V

	Maximum DC Current per I/O Pin	
● with operating voltage 5 V		20 mA
● with operating voltage 3 V		10 mA

more electrical characteristics you will find on the page 365 in the data sheet [AT90CAN128.pdf](#)

- ▶ Voltage Suppressor P6SMB6.8A
- ▶ 2-layer PCB DIN ISO 9001
- ▶ with UL-Approbation
- ▶ 4x LED yellow 2V 20 mA 140° 39 mcd

## Possible Modifications

- ▣ with mounted quartz (without quartz socket)
- ▣ without laterally pins

# Programming

## JTAG <sup>1</sup>

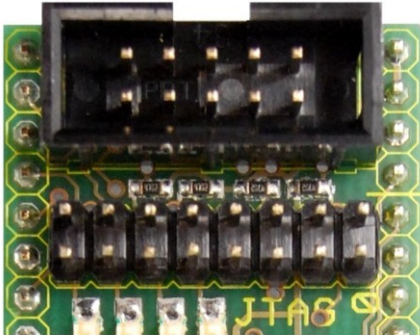

## ISP <sup>2</sup>

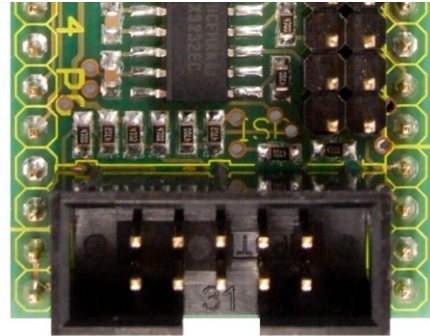

### *Pin Configuration JTAG-Connector*

(9) TDI	(7) VCC	(5) TMS	(3) TDO	(1) TCK
(10) GND	(8)	(6) Reset	(4) VCC	(2) GND

### *Pin Configuration ISP-Connector*

(2) VCC	(4) GND	(6) GND	(8) GND	(10) GND
(1) MOSI	(3) GND	(5) Reset	(7) SCK	(9) MISO

**1** When programming with JTAG the JPI-(1-4)-jumpers should be set.

**2** When programming with ISP the UART-jumpers JP2-3 and JP2-1 should not be set.

# Settings

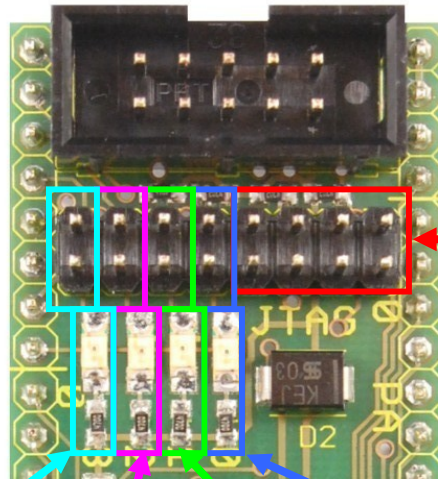

JTAG-jumpers JP1-(1-4)

When programming with JTAG the jumpers should be set in the red square.

<b>LED-jumper 3</b> +LED 3 (yellow) +resistor  Jumper is connected to the pin PF3	<b>LED-jumper 2</b> +LED 2 (yellow) +resistor  Jumper is connected to the pin PF2	<b>LED-jumper 1</b> +LED 1 (yellow) +resistor  Jumper is connected to the pin PF1	<b>LED-jumper 0</b> +LED 0 (yellow) +resistor  Jumper is connected to the pin PF0
---	---	---	---

## Jumpers set-up

<b>JP1-8</b>	<b>JP1-7</b>	<b>JP1-6</b>	<b>JP1-5</b>	<b>JP1-4</b>	<b>JP1-3</b>	<b>JP1-2</b>	<b>JP1-1</b>
<b>LED 3</b> Pin PF3	<b>LED 2</b> Pin PF2	<b>LED 1</b> Pin PF1	<b>LED 0</b> Pin PF0	<b>TDI</b> Pin PF7	<b>TDO</b> Pin PF6	<b>TMS</b> Pin PF5	<b>TCK</b> Pin PF4



Quartz socket

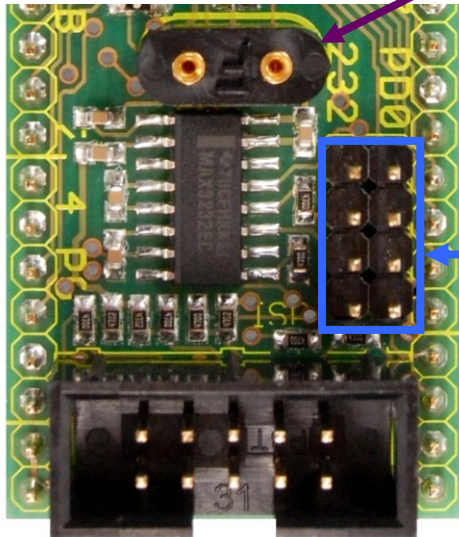

UARTs-jumpers

JP2-4	PD2
JP2-3	PE0
JP2-2	PD3
JP2-1	PE1

The UARTs-pins can be parted from RS232 transceivers with these jumpers.

**When programming with ISP the UART-jumpers JP2-3 (PE0) and JP2-1 (PE1) should not be set.**

Connection of D-SUB 9-pin female connector (serial port/COM1)

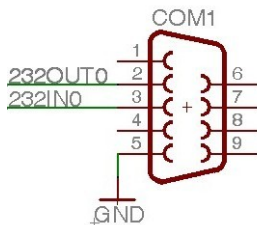

	D-SUB 9-p.	AL-AVREB_CAN
CH 0 example in the left picture	Pin 2	36_232OUT0
	Pin 3	34_232IN0
	GND	32_GND
CH 1	Pin 2	35_232OUT1
	Pin 3	33_232IN1
	GND	32_GND